

### Retrofit Kit for Transport Belt Drive

Dear customer,

The transport belts of your ROVEMA packaging machine are of great importance for a reliable and efficient production. However, the bearings and the drive unit are subject to considerable wear. Moreover, an exchange of these components is always connected to a production stop and complicated installation work.

ROVEMA offers you a retrofit kit for the drive of the transport belt with which the operational life of the bearings and the drive unit will be significantly prolonged. With our retrofit kit, existing parts like roller shaft and drive shaft can be replaced and a coupling with adapter flange can be retrofitted. Convincing advantages are an increased running smoothness of the drive unit, a gentle motion sequence as well as less wear of the bearings and the drive unit.

#### The retrofit kit for the transport belt drive offers you:

- less wear of bearings and drive unit
- longer operating life of the wear parts
- relief of the gear unit by an increased running smoothness
- reduction of unplanned downtimes
- constant machine availability

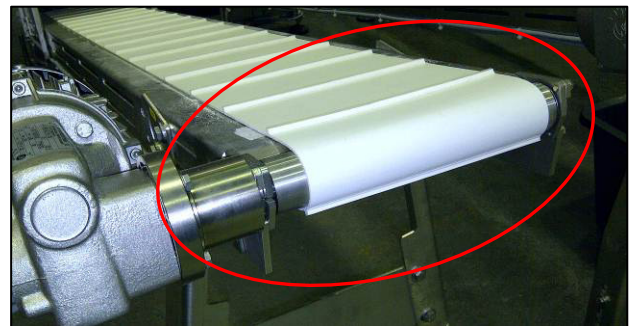

*transport belt with roller shaft*

#### The retrofit kit contains:

- roller shaft with holder and set of ball bearings
- drive shaft for gear motor
- coupling with adapter flange for the gear
- mounting material

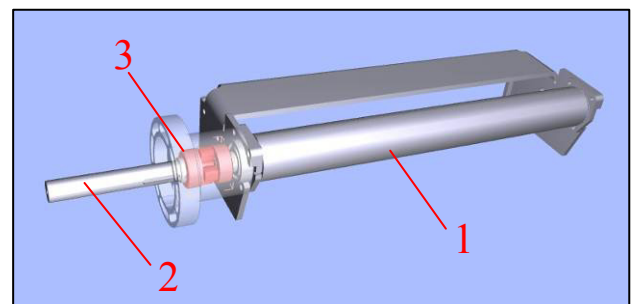

- 1 roller shaft
- 2 drive shaft for gear motor
- 3 coupling with adapter flange

We will gladly issue an offer for the installation on site at your ROVEMA transport systems by our service technicians.

For more information about the retrofit kit for the transport belt drive as well as prices and delivery times or in case of questions regarding your ROVEMA packaging machine, your contact persons at ROVEMA Service are always at your disposal.

Your ROVEMA Service Team