

Lifting Device for Film Rolls

Dear customer,

The creation of safe and ergonomic working conditions for operating and maintenance personnel is a declared goal of many companies worldwide.

The new lifting device for film rolls for your ROVEMA form, fill and seal machine is a helpful tool which considerably reduces both the accident risk as well as the health burden for your operating personnel. At the same time it shortens the set-up time for film roll changes. With this motor-driven device, heavy film rolls with a weight of sometimes more than 100 kg can be effortlessly lifted to their designated position in the reel carrier of the machine. The lifting device is especially suited for large-scale machines, film rolls with a diameter of 600 mm and heavy multilayered film types with metal content.

The lifting device for film rolls offers you:

- increase of occupational safety
- reduction of health burden for your operating personnel
- considerable reduction of set-up time
- gentle handling of sensitive packaging materials
- easy operation with automatic switch-off

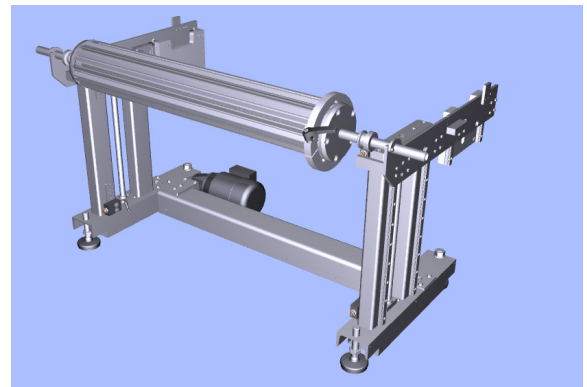

The retrofit kit “lifting device” contains:

- lifting device with pedestal
- motor-driven spindle adjustment
- operator button for up and down movement
- sampler for automatic switch-off
- connection material and accessories



*view lifting device in a ROVEMA
form, fill and seal machine*

We will gladly issue an offer for installation and commissioning (duration approx. 1 day plus travel time) on site at your ROVEMA machine. The lifting device can be retrofitted on all ROVEMA form, fill and seal machines (also if integrated in a SBS or CMV machine).

For more information about the lifting device for film rolls as well as prices and delivery times or in case of questions regarding your ROVEMA packaging machine, your contact persons at ROVEMA Service are always at your disposal.

Your ROVEMA Service Team